

OPERATOR'S MANUAL

WITH WARRANTY



410SP STAND-ON TOPDRESSER

Earth&Turf

America's Compact Topdresser Company

**1867 Kirkwood Pike
Kirkwood, Pennsylvania 17536
888-693-2638**



AUGUST 2025

410SP TABLE OF CONTENTS

Safety Precautions	03
Transport	04
Dashboard Layout	05
Operating Instructions	06
Recommended Daily Maintenance	10
Settings and Materials	11
Maintenance Guide	12
Specifications	20
Troubleshooting.....	21
Limited Warranty.....	23

410SP SAFETY PRECAUTIONS

IMPORTANT SAFETY PRECAUTIONS

DANGER!!

OPERATOR MUST READ BEFORE USING UNIT

Read and understand all instructions before operating this machine. If you do not understand any instructions, refer to someone who does. Failure to do so may result in serious injury or death.

- **ALWAYS** turn off engine and engage parking brake before dismounting.
- **NEVER** turn or travel with parking brake engaged.
- **KEEP HANDS AWAY** from any moving parts of the spreader during operations.
- **NEVER** run machine unless all guards are securely in place.
- **NEVER** repair any parts or make adjustments while machine is in motion.
- **NEVER** wear loose clothing around any moving parts of the machine.
- **NEVER** allow anyone to ride inside or any position other than one operator on the standing plate of the spreader.
- **ALWAYS** operate while standing two feet on the riding platform. (Loading on trailer may be an exception.)
- **ALWAYS** take caution with hills, ramps and unsure areas. When unsure if the angle is appropriate, do not try it! Do not travel sideways on hills over 5° grade or up/down hills over 16° grade.
- **ALWAYS** run the machine outdoors, **NEVER** indoors, carbon monoxide **KILLS**.
- **ALWAYS** reduce speed for safe turns.

410SP TRANSPORT

Failure to secure machine may result in serious injury or death.

- 1. Apply Parking Brake**– Once in position on trailer, apply parking brake. To apply press down with foot on brake pad marked “P”. (To release, kick the release pad.)
- 2. Front Tie Down** – Use front tie down to strap front of unit to the trailer.
- 3. Rear Tie Down** – Use rear tiedown to strap rear of unit to the trailer.
- 4. Gas valve.** Be sure to close gas valve when transporting. Valve is located on the left side of the engine as shown.

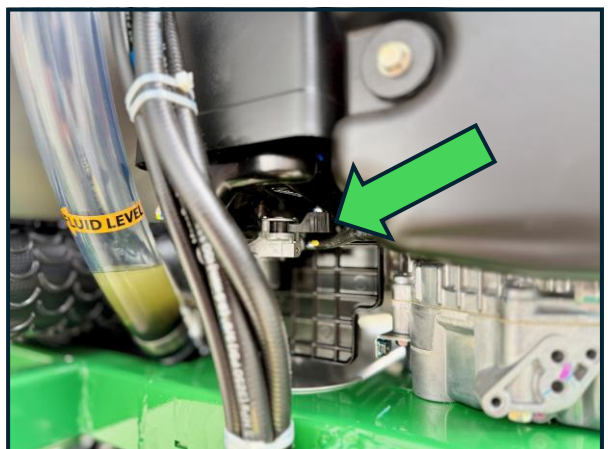
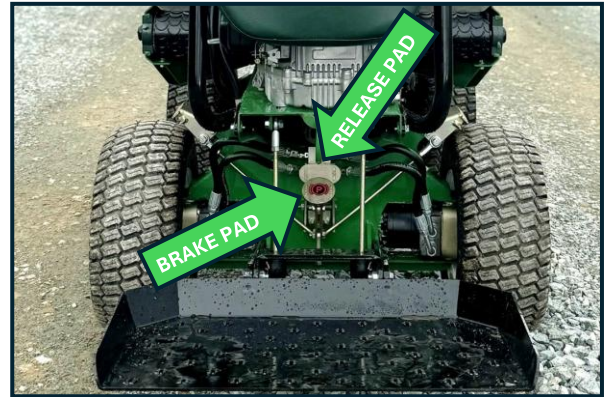

410SP DASHBOARD

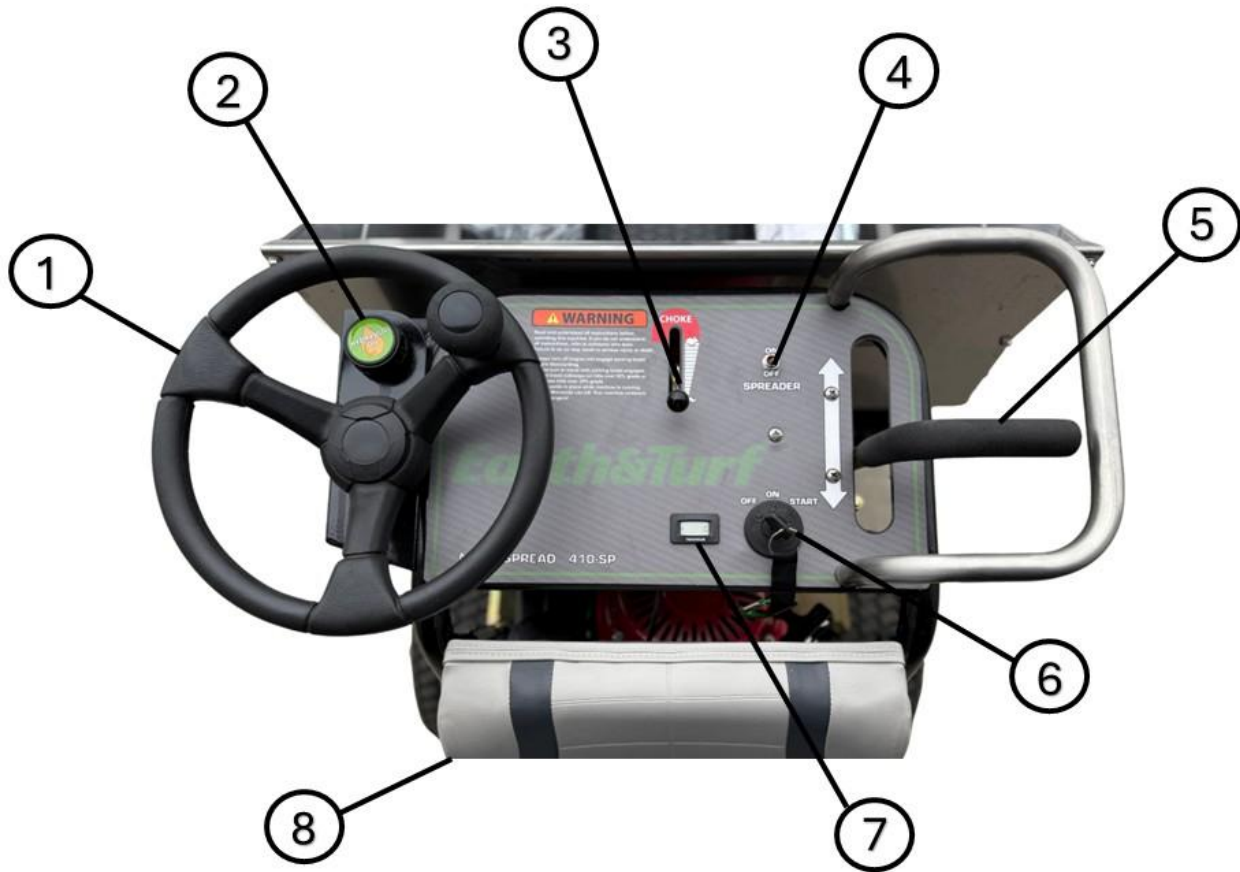

- | | |
|-------------------------------|----------------------------------------|
| 1. STEERING WHEEL | 5. DIRECTIONAL CONTROL FORWARD/REVERSE |
| 2. HYDROSTATIC FLUID FILL | 6. KEY IGNITION |
| 3. THROTTLE AND CHOKE | 7. TACHOMETER/HOUR METER |
| 4. SPREADER ENGAGEMENT SWITCH | 8. HIP CUSHION |

410SP OPERATION

- 1. STEERING WHEEL** – Steers all 4 wheels in sync for a smooth sharp turn. Operator should take caution and drive slowly to get familiar with 4-wheel steering. The machine will sweep operator station to the side when steering, unlike a front steering machine. It may take time to get used to. On the wheel is a rotating knob for quick, responsive one-handed steering.



- 2. HYDROSTATIC OIL FILL** – Use a small funnel to avoid spillage. See changing instructions on page 18. Area should be cleaned before removing cap to avoid fluid contamination.



- 3. THROTTLE & CHOKE LEVER** – Push upwards, increasing speed for smooth hydraulic operation. Leave on idle for loading to ensure hydraulic fluid circulates. To choke the engine for starting, push all the way to the top. **Pull lever backwards out of choke once started.**



410SP OPERATION

4. **ENGAGING THE SPREADER** – Flip the toggle switch into the upward position to engage the belt . When toggle is in the upward position, the belt will creep forward as the operator drives forward, then stops when the machine stops. This is part of the calibration, spreading at a speed that matches your ground speed, not faster or slower, but consistent.

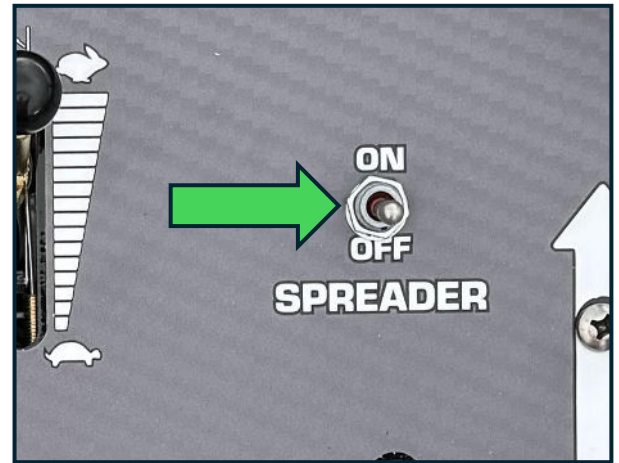

5. **Direction Control** – This lever engages wheel motors in the forward or reverse direction. To move the machine, simply push the lever in the desired direction of travel. Always stand on the machine platform when moving forward or reverse to avoid serious injury or death. **NOTE:** Drive lever will not move while parking brake is engaged to ensure no damage to tires.

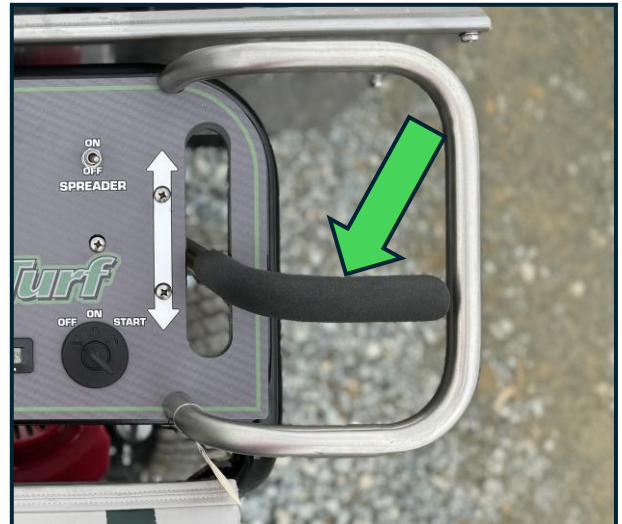

6. **Key Ignition** – Turn all the way to the right to start and then release once started. It may require the use of the choke when starting unit cold.



410SP OPERATION

7. **TACHOMETER/HOUR METER** –
Displays the current rpm while running.
Displays the total amount of engine running hours when engine is not running.

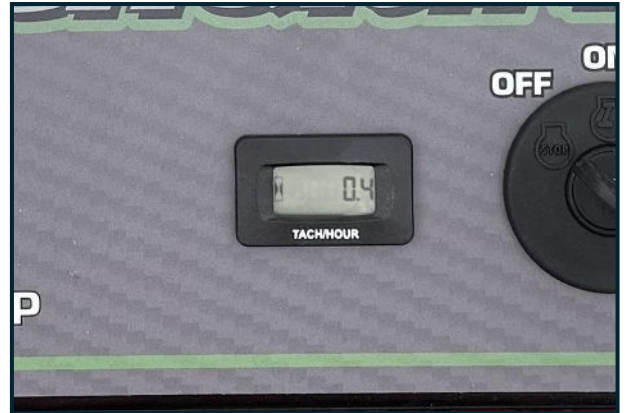

8. **Hip Cushion** – For access to the engine, remove the cushion. Remove by pulling up on the cushion assembly. To install, first place upper hooks in slots, then place lower hooks in their slots and push downwards on cushion assembly until hooks slide into place. (At some point after use wear, it may be best to remove the cushion for transport. At transporter's discretion.)

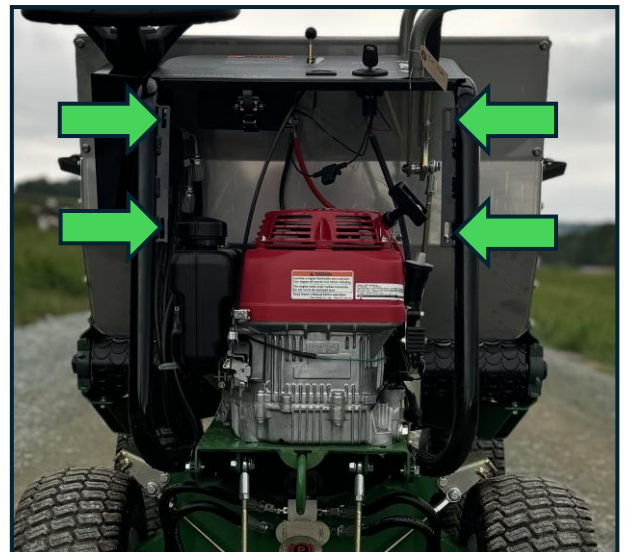

410SP OPERATION

9. **Parking Brake** – Locks rear wheels for transport on truck/trailer. (**Straps are still required for safe transit**). Also locks rear wheels to park while reloading, etc. While locked down, driver will not be able to operate forward/reverse due to parking brake lockout. To release, kick the release pad. (Shown in lower picture)

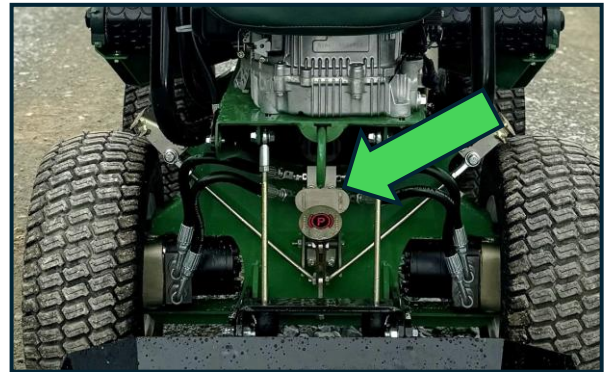
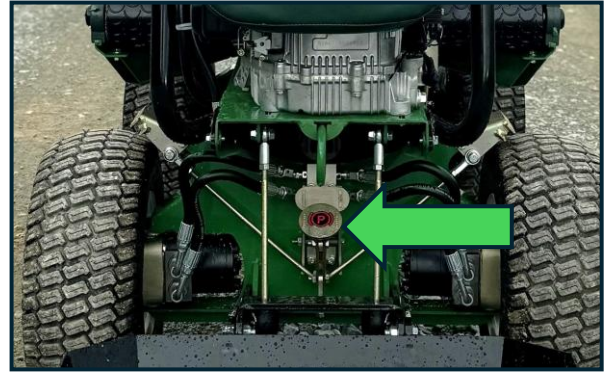

10. **GAS FILL** – We recommend refilling with a short funnel after engine is allowed to cool.



410SP RECOMMENDED DAILY MAINTENANCE

1. Operators must read before using unit.
2. Entire unit must be washed thoroughly after each use. **NEVER** store material in spreader.
3. Maintain proper air pressure (22psi) in tires to ensure proper operation.
4. Lug nuts should be tightened to 120 ft. lbs.
5. Drive chain and steering cylinder ball joint requires proper graphite lubrication.
6. All shields **MUST** be in place while operating this unit.
7. Check engine oil. The dip stick is to be up to the “full” line as marked. Use 10W-30 premium synthetic motor oil.
8. Check hydrostatic fluid reservoir level by viewing clear fill tube on left side of the machine. Level should be approximately 2” above frame when cold. Use a premium 15W-40 or 20W-50 synthetic hydrostatic fluid.
9. Check conveyor belt for tightness, tighten belt in half turn increments.
10. If conveyor belt is still loose after fully tightening , replace belt.



2&5. ENTIRE UNIT WASH AND LUBRICATION



9. ADJUSTING THE TENSION ON THE CONVEYOR BELT



10. REPLACEMENT OF THE CONVEYOR BELT

410SP SETTINGS & MATERIAL GUIDE

TOPDRESSER

All topdressing Materials vary due to moisture, density, and source. Topdressing hopper spreads but is not limited to the following materials.

- Sand
- Compost
- Topsoil (screened)
- Crumb rubber
- Coconut husks and cork

Though it may spread, it is not designed or warranted for use with

- Lime
- Stone
- Mulch
- Cement dust
- Fertilizer (granular or pulverized)

*NOTE: End users are responsible to spread and test material to assure desired coverage is reached, material coverage will vary with consistency and moisture. Topdressing belt will move according to ground speed.

Flow Rate – Topdresser Settings*

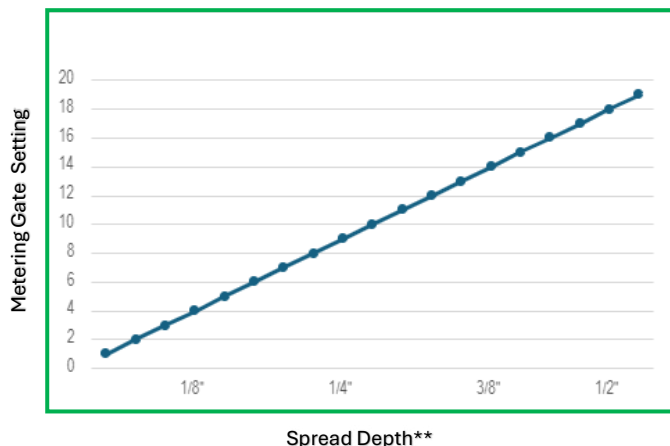

**Flow rates depicted on graph will vary with moisture content, product consistency amongst other variables. Charts are meant to give initial guidance towards desired rate determination.

410SP MAINTENANCE GUIDE

CLEANING YOUR 410SP

1. After each use the machine should be pressure washed thoroughly. Collected material may damage moving parts, material belt, and roller chains. Refer to video listed on page 10.
2. To clean out conveyor belt pressure wash inside each access hole from both sides of the machine while cycling the material belt. Continue cycling belt until draining water is clear of debris. Accumulation of material on belt rollers will damage conveyor belt.
3. Chain shields should be pressure washed from inside out or remove the shield to clean sand and compost prior to lubrication, alongside of cleaning the belt. The shields should be removed after a minimum of every 40 hours of use. Thoroughly clean the chains and area from all debris, relubricate chains and sprockets as directed and replace shields. (See page 10)
4. While the entire machine may be pressure washed thoroughly, electronics, dashboard and engine should not be directly washed with high pressure or turbo tip.

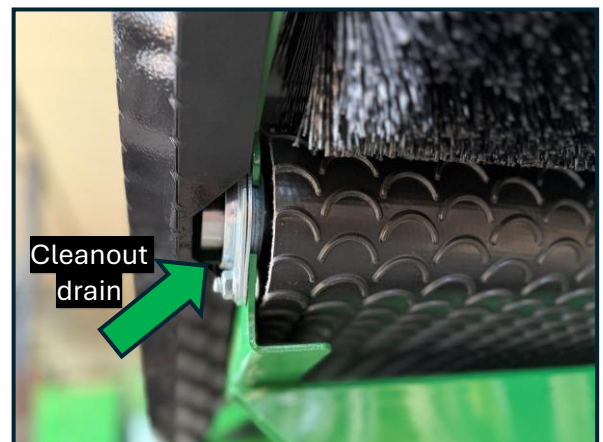
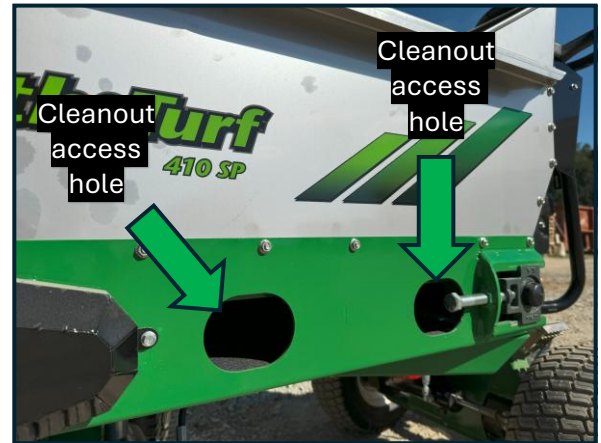

410SP MAINTENANCE GUIDE

CLEANING YOUR 410SP (continued)

1. After each use check the area between the gas tank/air filter and the engine. This is where the engine choke resides. The area can become packed with compost/sand and other debris, causing the choke to malfunction and not disengage. This can damage your engine.

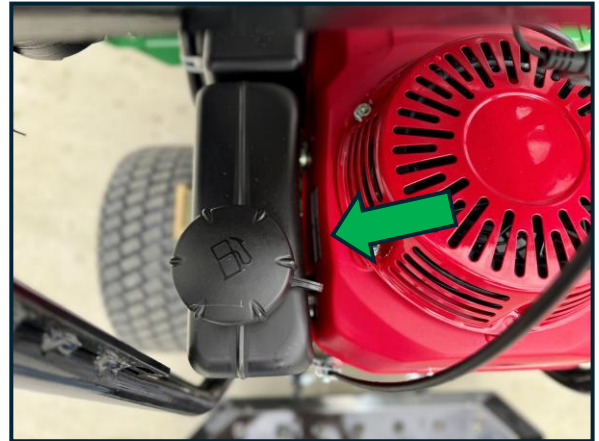

410SP MAINTENANCE GUIDE

CONVEYOR BELT CHAIN ROUTING

1. Routing



2. Guard attachment.

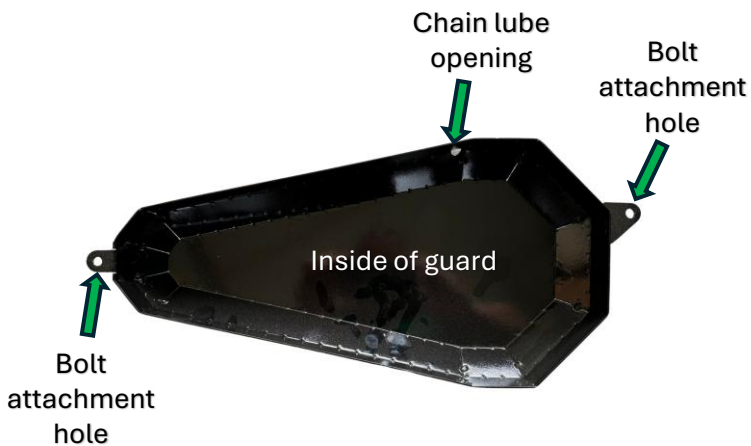

EXPELLER BRUSH CHAIN ROUTING

1. Routing: Pre-September 2024 Models



2. Routing: Post-September 2024 Models



3. Guard attachment

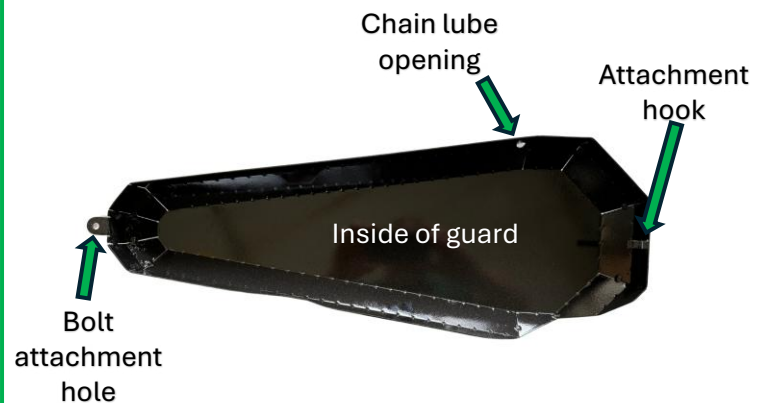

410SP MAINTENANCE GUIDE

FUSE REPLACEMENT

1. One 10 AMP fuse is located under the dash behind the hip cushion. Open fuse holder to replace fuse as needed.

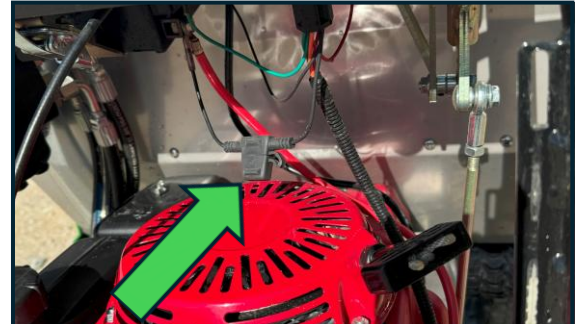

GREASING AND LUBRICATING

1. With a dry lube spray, lubricate the steering cylinder shaft and ball-socket on both front and back (front shown) as often as you lubricate the chains. **Be sure to clean the area thoroughly after each use.**
2. Grease zerk at front axle swivel pin every 50 hours or as needed.
3. Grease zerk on rear belt rollers as need. **Use CAUTION:** as these are sealed bearings, over greasing will destroy the seals. We recommend one pump every 50 hrs.

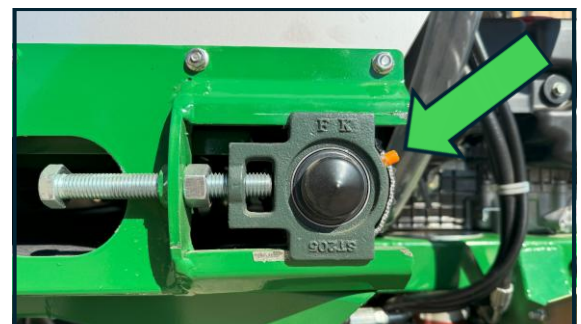
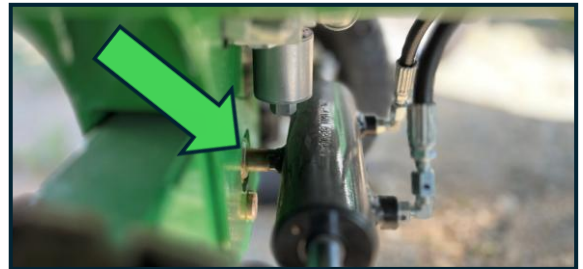

410SP MAINTENANCE GUIDE

GREASING AND LUBRICATING

1. Lubricate brush chain through hole in shield every 10 hours of operation. We recommend using an industrial graphite dry lubricant. The shields should be removed after a minimum of every 40 hours of use. Thoroughly clean the chains and area from all debris, relubricate chains and sprockets as directed and replace shields.
2. Lubricate belt chain through hole in shield every 10 hours of operation. We recommend using an industrial graphite dry lubricant. The shields should be removed after a minimum of every 40 hours of use. Thoroughly clean the chains and area from all debris, relubricate chains and sprockets as directed and replace shields.

REPLACING AIR FILTER

1. The air filter is located behind the gas tank on the left side of the engine. Remove cover and replace filter every 100 hours of operation or sooner if needed. Please see video.



410SP MAINTENANCE GUIDE

CONVEYOR BELT TIGHTENING

1. Use a 15/16" wrench to tighten conveyor or adjust when walking to the side. To tighten belt, loosen lock nut and turn bolt head a precise amount of turns that directionally move the bolt head towards the bearing (tightening towards the back of the machine). With one side completed, tighten lock nut and proceed with the same function on opposite side. **IMPORTANT:** if the belt was tracking correct, but not tight enough, track the amount of turns and be sure to do the same on each side. Otherwise, the material belt will track incorrectly to one side.

2. If material belt is tracking incorrectly, tighten the loose side in small increments (2-5 turns depending how much is needed) and run the belt to test it and work it back into position. Do not tighten more than 5 turns at a time or the belt may be imbalanced to the opposing side, causing the inverse issue. Cycle belt for at least 6 revolutions of the lacing to determine final adjustment is made and ready for more material.



410 Belt Tightening Instructions

410SP MAINTENANCE GUIDE

ENGINE OIL CHANGE

1. Engine oil should be changed after the first 20 hours or 1 month. After first oil change the engine oil should be changed every 100 hours of use or 6 months, whichever comes first.
2. To change engine oil: Drain current oil into pan with a minimum of 1 gallon capacity. With oil drained and no oil continually flowing out of the drain, replace the plug and tighten to ensure no further drainage.



3. Oil fill tube can be found on the right side of the engine. To fill engine with new oil, use a funnel to prevent spillage.
4. Engine oil capacity is **1.2 US quarts 10W 30 synthetic engine oil**. Once filled, remove funnel and replace fill cap. Wipe all surfaces clean to remove residual oil.
5. Check final engine oil level with engine dipstick located at the right rear of your machine.



410SP MAINTENANCE GUIDE

HYDROSTATIC FLUID CHANGE

1. Hydrostatic fluid should be changed after the first 50 hours, then again, every 250 hours of use or annually, whichever comes first. Drain current fluid into fluid drain pan with 5-gallon capacity.



2. With fluid drained and no fluid continually flowing out of the fitting, replace the cap and tighten to ensure no further drainage.



3. Replace the hydrostatic fluid filter (**Baldwin Part #BT8409 or Equivalent**). The filter can be found on the bottom of the reservoir tank.



4. Hydrostatic fluid fill cap is located to the left of the dashboard. To fill the reservoir with new oil, use a small funnel to avoid spillage. Hydraulic oil capacity is **1.75 US gallons (15W 40 or 20W 50 fully synthetic hydrostatic fluid)**. Once filled, remove funnel and replace fill cap. Wipe all surfaces clean to remove residual fluid.



⚠ DANGER	
	High Pressure Fluid Hazard. High pressure fluid leak will pierce skin. Release pressure before working on system.
	Detect leaks with wood or cardboard. Wear sturdy gloves and goggles. NEVER use fingers. Fluid injected in skin must be surgically removed by trained doctor immediately or gangrene will result. Fluid injected into skin will injure or kill.
<small>FAMA29 Do not paint over this label. Replace if damaged or lost.</small>	

410SP SPECIFICATIONS

- Capacity:** 8 cu. ft. struck level
- Max Load Weight:** 800 lbs. (362.87 kg)
- Box Width:** 30.25" (76.84 cm)
- Box Length:** 38.5" (97.79 cm)
- Box Height:** 12" (30.48 cm)
- Total Width:** 35" (88.90 cm)
- Total Length:** 82" (208.28 cm)
- Total Height:** 47.5" (120.65 cm)
- Spread Thickness:** up to 1/2" (1.27 cm)
- Spread Width:** 30" (76.2 cm)
- Spread System:** Hydraulic Belt & Brush Expeller
- Unit Weight:** 830 lbs. (376.48 kg)
- Gross Weight Max:** 1,830 lbs. (830.07 kg)
- Drive:** Hydraulic Wheel Motors
- Engine:** GXV390 (13HP)
- Maximum Speed:** 5MPH

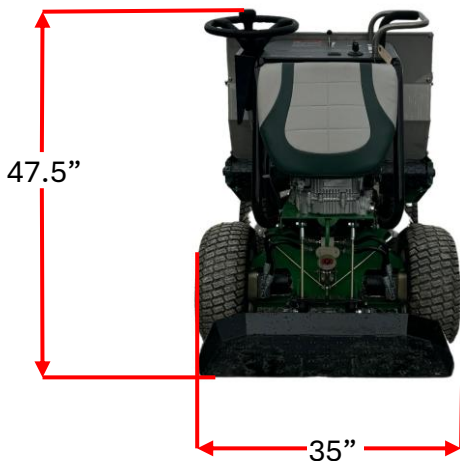

410SP TROUBLE SHOOTING

❑ Engine won't start?

- Check battery voltage and attempt jump start.
- Check wiring and connections to ensure all fittings are tight and not hindered.
- Check gas valve on left side of engine to verify the gas valve is on.

❑ Belt Won't move?

- Material jammed
- Check to see if the belt is tight enough
- Gate open, clean out
- Check to see if the belt chain is engaged and intact

❑ Hydrostatic fluid fitting leaking?

- Tighten fitting
- Clean and run, check in 20 minutes of use
- Check fitting crimp

❑ Machine whining loudly?

- Let it warm up
- Check hydrostatic fluid level to ensure reservoir has proper fluid level in the tank

❑ Unit is running dog legged?

- With your 410 running in neutral, turn the steering wheel all the way to the left and then all the way to the right. Then back to neutral.

410SP TROUBLE SHOOTING

- ❑ 410SP is disabled from operating and I need to tow it onto the trailer without running the machine?

- Loosen this bolt (using a 5/8" open end wrench) to free your 410SP for towing. **Tow slowly and only if necessary.**



- QR code



410SP WARRANTY

LIMITED WARRANTY

Earth & Turf Products, a DBA of Conestoga Manufacturing warrants to the original purchaser, all Earth & Turf products, manufactured by it, to be free from defects in both material and workmanship under normal use and service. Earth & Turf Products, obligation under this warranty shall be limited to replacement or repair of any parts thereof, free of charge to the original purchaser, at its place of business, provided, however, that the part(s) to be replaced or repaired, shall within 1 year after delivery to the original purchaser, be demonstrated to be defective: which determination shall be made by company.

The said components or parts must be returned through the selling dealer or distributor directly to the company with all transportation charges prepaid. Notice of defects shall be furnished in writing to the seller and to the agent through whom the machinery was received, disclosing in full all known defects and failure in operation and use, and reasonable time shall be given to the seller to remedy any such defects and failures. Failure to make such trial or to give such notice shall be deemed an absolute acceptance by the buyer and satisfaction in full of this limited warranty. Under no circumstances does this warranty cover normal wear of any parts, components or material which, in the opinion of the seller and the company, have been subjected to neglect, misuse, alteration, accident, or if repaired, with parts other than those manufactured by and obtained from Earth & Turf Products. This warranty does not cover components which are already covered by a separate warranty provided by the supplier of said parts or components. Earth & Turf Products, obligation under this warranty is limited to repair or replacement, free of charge to the original purchaser, of any part which in the judgement of the company is defective. The company makes no warranty whatsoever in respect to accessories or parts not supplied by the company. The term "original purchaser", as used in this warranty, shall be deemed to mean that person for whom the product is originally supplied.

The company, under this warranty, cannot guarantee that existing conditions beyond its control will not affect its ability to obtain materials or manufacture necessary replacement parts. The company reserves the right to make design changes, or specifications at anytime, without any contingent obligation on its parts to purchasers of machines and parts previously sold. No one is authorized to alter, modify or change the terms of this warranty in any manner. The company warrants the construction of the equipment sold herein and will replace it at its expense for a period of one year from the date hereof, any parts which prove defective as determined under the terms of this limited warranty. This warranty shall apply only within the boundaries of the continental United States.

THIS WARRANTY IS MADE EXPRESSLY IN LIEU OF ALL OTHER WARRANTIES, EXPRESSED OR IMPLIED, INCLUDING ANY WARRANTY OF MERCHANTABILITY AND FITNESS FOR USE AND PURPOSE AND OF ALL OTHER OBLIGATIONS OR LIABILITIES ON ITS PART AND ANY IMPLIED PERSON TO ASSUME FOR IT, ANY OTHER LIABILITY IN CONNECTION WITH A SALE OF THESE PRODUCTS. THIS WARRANTY SHALL NOT APPLY TO THESE PRODUCTS OR TO ANY PART THEREOF WHICH HAS BEEN SUBJECT TO ACCIDENT, NEGLIGENCE, ALTERATION, ABUSE OR MISUSE.

Earth & Turf

America's Compact Topdresser Company

**1867 Kirkwood Pike
Kirkwood, Pennsylvania 17536
888-693-2638**

