

PARTS MANUAL

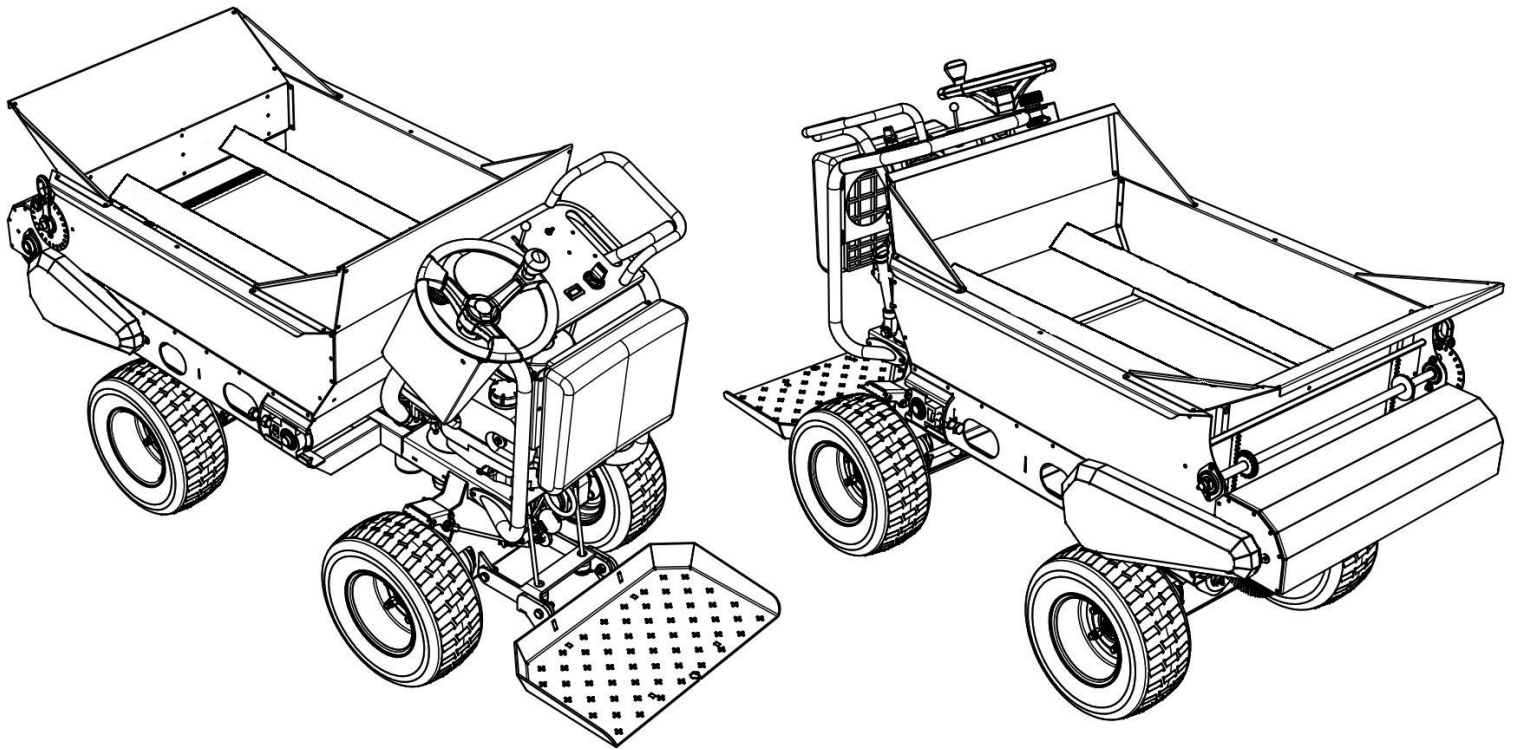

410SP STAND-ON TOPDRESSER

Earth & Turf

America's Compact Topdresser Company

**1867 Kirkwood Pike
Kirkwood, Pennsylvania 17536
888-693-2638**



410SP TABLE OF CONTENTS

Safety Precautions	03
Chassis Parts	04
Spreader Box Parts.....	06
Dashboard Assembly Parts.....	08
Hydrostatic Fluid Reservoir Parts	09
Electrical & Hydrostatic Schematics.....	10
Hydrostatic Hoses.....	13
Limited Warranty.....	17

410SP SAFETY PRECAUTIONS

IMPORTANT SAFETY PRECAUTIONS

DANGER!!

OPERATOR MUST READ BEFORE USING UNIT

Read and understand all instructions before operating this machine. If you do not understand any instructions, refer to someone who does. Failure to do so may result in serious injury or death.

- **ALWAYS** turn off engine and engage parking brake before dismounting.
- **NEVER** turn or travel with parking brake engaged.
- **KEEP HANDS AWAY** from any moving parts of the spreader during operations.
- **NEVER** run machine unless all guards are securely in place.
- **NEVER** repair any parts or make adjustments while machine is in motion.
- **NEVER** wear loose clothing around any moving parts of the machine.
- **NEVER** allow anyone to ride inside or any position other than one operator on the standing plate of the spreader.
- **ALWAYS** operate while standing two feet on the riding platform. (Loading on trailer may be an exception.)
- **ALWAYS** take caution with hills, ramps and unsure areas. When unsure if the angle is appropriate, do not try it! Do not travel sideways on hills over 5° grade or up/down hills over 16° grade.
- **ALWAYS** run the machine outdoors, **NEVER** indoors, carbon monoxide **KILLS**.
- **ALWAYS** reduce speed for safe turns.

410SP WARRANTY

LIMITED WARRANTY

Earth & Turf Products, a DBA of Conestoga Manufacturing warrants to the original purchaser, all Earth & Turf products, manufactured by it, to be free from defects in both material and workmanship under normal use and service. Earth & Turf Products, obligation under this warranty shall be limited to replacement or repair of any parts thereof, free of charge to the original purchaser, at its place of business, provided, however, that the part(s) to be replaced or repaired, shall within 1 year after delivery to the original purchaser, be demonstrated to be defective: which determination shall be made by company.

The said components or parts must be returned through the selling dealer or distributor directly to the company with all transportation charges prepaid. Notice of defects shall be furnished in writing to the seller and to the agent through whom the machinery was received, disclosing in full all known defects and failure in operation and use, and reasonable time shall be given to the seller to remedy any such defects and failures. Failure to make such trial or to give such notice shall be deemed an absolute acceptance by the buyer and satisfaction in full of this limited warranty. Under no circumstances does this warranty cover normal wear of any parts, components or material which, in the opinion of the seller and the company, have been subjected to neglect, misuse, alteration, accident, or if repaired, with parts other than those manufactured by and obtained from Earth & Turf Products. This warranty does not cover components which are already covered by a separate warranty provided by the supplier of said parts or components. Earth & Turf Products, obligation under this warranty is limited to repair or replacement, free of charge to the original purchaser, of any part which in the judgement of the company is defective. The company makes no warranty whatsoever in respect to accessories or parts not supplied by the company. The term "original purchaser", as used in this warranty, shall be deemed to mean that person for whom the product is originally supplied.

The company, under this warranty, cannot guarantee that existing conditions beyond its control will not affect its ability to obtain materials or manufacture necessary replacement parts. The company reserves the right to make design changes, or specifications at anytime, without any contingent obligation on its parts to purchasers of machines and parts previously sold. No one is authorized to alter, modify or change the terms of this warranty in any manner. The company warrants the construction of the equipment sold herein and will replace it at its expense for a period of one year from the date hereof, any parts which prove defective as determined under the terms of this limited warranty. This warranty shall apply only within the boundaries of the continental United States.

THIS WARRANTY IS MADE EXPRESSLY IN LIEU OF ALL OTHER WARRANTIES, EXPRESSED OR IMPLIED, INCLUDING ANY WARRANTY OF MERCHANTABILITY AND FITNESS FOR USE AND PURPOSE AND OF ALL OTHER OBLIGATIONS OR LIABILITIES ON ITS PART AND ANY IMPLIED PERSON TO ASSUME FOR IT, ANY OTHER LIABILITY IN CONNECTION WITH A SALE OF THESE PRODUCTS. THIS WARRANTY SHALL NOT APPLY TO THESE PRODUCTS OR TO ANY PART THEREOF WHICH HAS BEEN SUBJECT TO ACCIDENT, NEGLIGENCE, ALTERATION, ABUSE OR MISUSE.

410SP CHASSIS ASSEMBLY

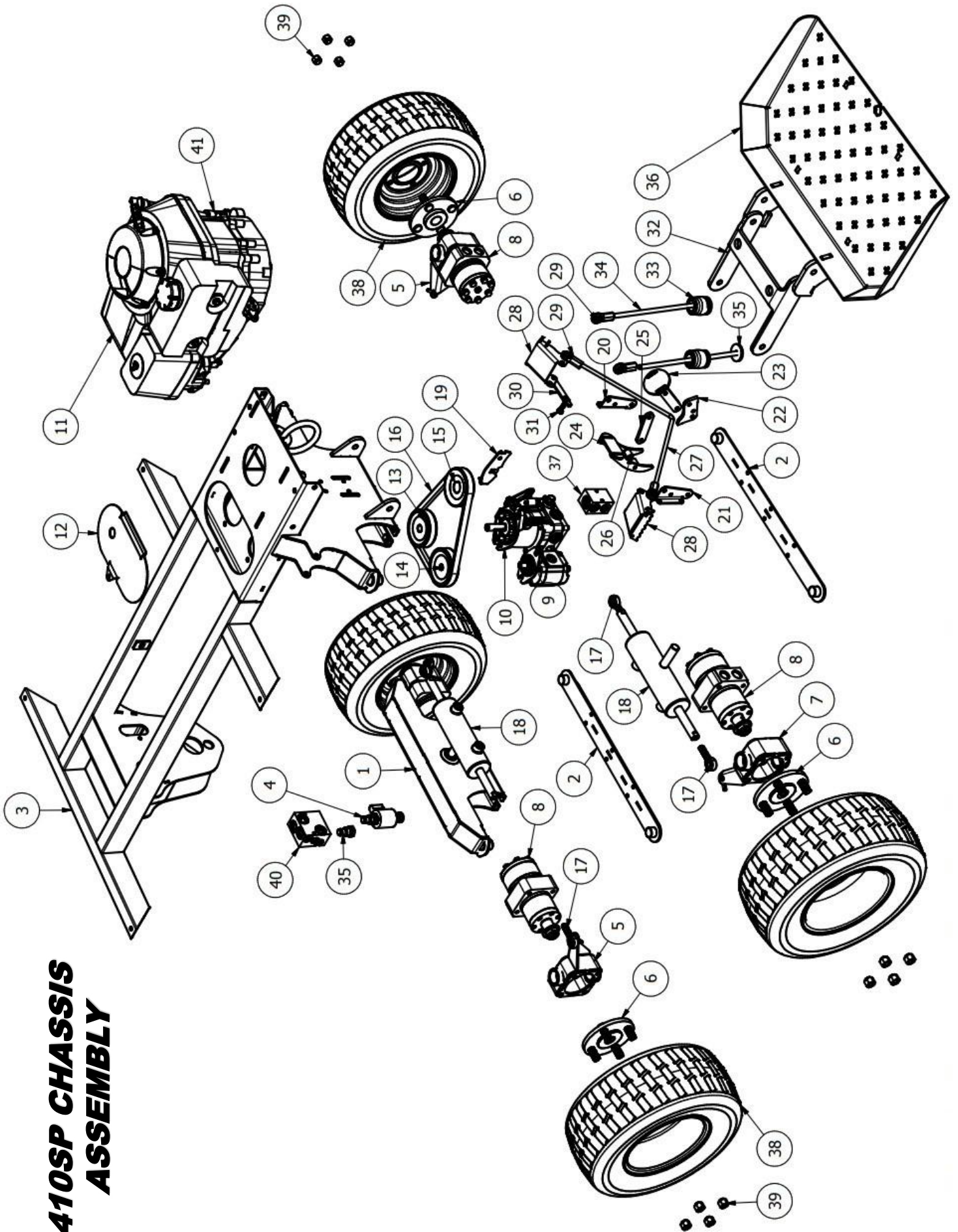

410SP CHASSIS PARTS LIST

ITEM	QTY	PART NUMBER	DESCRIPTION
1	1	CMP41711	Front Axle Assembly
2	2	CMP41712	Axle Bottom Rib Assembly
3	1	CMP41700	Under Carriage Assembly
4	1	CMP41703	Solenoid Valve
5	2	CMP41706LF	Wheel Motor Bracket LF RR
6	4	CMP41713	Wheel Hub Assembly
7	2	CMP41706RF	Wheel Motor Bracket RF LR
8	4	CMP41401	Wheel Motor CUM 319-3025
9	1	CMP41403	Gear Pump 6 109 1108 2
10	1	CMP41411	Hydrostatic Pump PK-BBBB-LB1X-XLXA
11	1	CMP41400	GXV 390 Honda Engine
12	1	CMP41096	Pump Shield
13	1	CMP41422	Hydro-Stat Pulley BK 34-5/8"
14	1	CMP41423	Gear Pump Pulley BK 34-1/2"
15	1	CMP41420	Engine Pulley BK 34-1"
16	1	CMP41421	Drive Belt Mc 6054K111, BK28
17	4	CMP41460	7/16" Rod End
18	2	CMP41714	Steering Cylinder Assembly
19	1	CMP41087	Pump Arm
20	1	CMP41081R	Park Mount R
21	1	CMP41081L	Park Mount L
22	1	CMP41084	Park Link
23	1	CMP41702	Park Pedal Assembly
24	1	CMP41715	Park Release Pedal Assembly
25	1	CMP41059	Top Park Link
26	2	CMP41240	Park Release Spacer
27	1	CMP41221	Park Rod
28	2	CMP41716	Park Clevis Assembly
29	4	CMP41436	3/8" Female Rod End
30	1	CMP41086	Lockout
31	1	CMP41479	Shoulder Bolt 5/16 Dia x5/16 L
32	1	CMP41047	Step Extension
33	2	CMP41472	GBA-107S Bumper
34	2	CMP41219	Platform Rods
35	2	CMP41066	Bumper Washer
36	1	CMP41720	Step Plate Assembly
37	1	CMP41413	Rear Manifold WH-2315
38	4	CMP41409	Hoosier 16x750-8 Tire
39	16	CMP41453	Lug Nut 1/2-20
40	1	CMP41413	Front Manifold WH-2315
41	1	CMP41498	Engine Filter
42	1	CMP41042	Front Axle Swival Pin

410SP SPREADER BOX ASSEMBLY

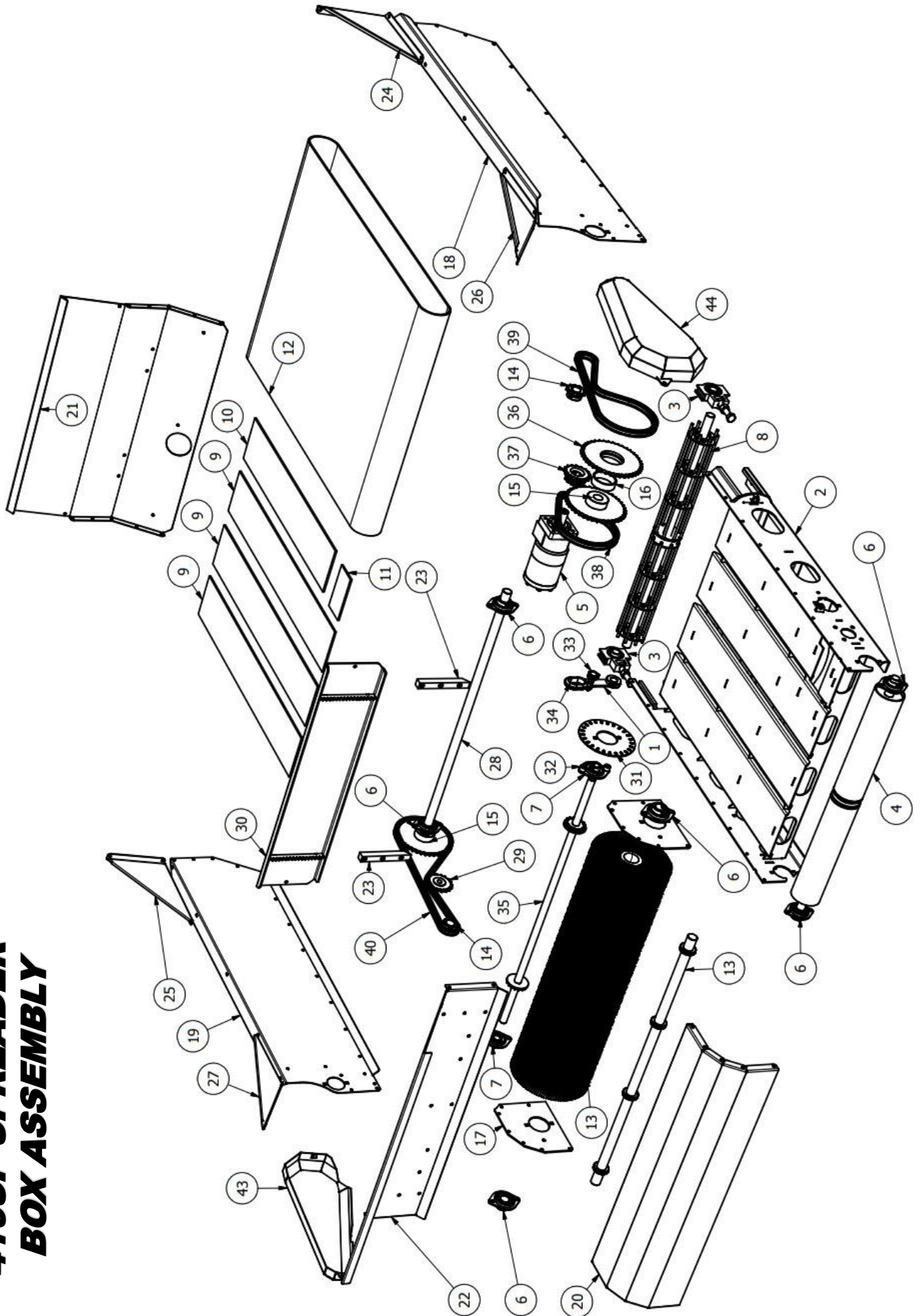

410SP SPREADER BOX PARTS LIST

ITEM	QTY	PART NUMBER	DESCRIPTION
1	1	CMP41707	Gate Handle Assembly
2	1	CMP41701	Bed Frame Assembly
3	2	CMP41424	Bearing Adj. Pillow Block
4	1	CMP41717	Conveyor Drive Roller
5	1	CMP41425	Belt & Brush Motor
6	6	CMP41428	Bearing Housing
7	2	CMP41441	Bearing Housing
8	1	CMP41718	Idler Open Roller Pulley
9	3	CMP41216	Flooring Guide 1
10	1	CMP41217	Flooring Guide 2
11	1	CMP41218	Flooring Guide 3
12	1	CMP41414	Black Crescent Top Belt
13	1	CMP41719	Brush Shaft Assembly
14	2	CMP41410	Sprocket
15	2	CMP41443	#40 Chain 40 Tooth Sprocket
16	1	CMP41454	Sprocket Bronze Bushing
17	2	CMP41024	Brush Mount
18	1	CMP41000L	Box Side L
19	1	CMP41000R	Box Side R
20	1	CMP41003	Brush Guard
21	1	CMP41002	Box Rear
22	1	CMP41001	Box Front
23	3	CMP41236	Slippery UHMW Polyethylene Bar
24	1	CMP41006L	Rear Flare L
25	1	CMP41006R	Rear Flare R
26	1	CMP41004L	Front Flare L
27	1	CMP41005R	Front Flare R
28	1	CMP41200	Jack Shaft
29	1	CMP41494	#40 Chain Idler Sprocket 18T
30	1	CMP41721	Metering Gate Assembly
31	1	CMP418009	Meter Adj.Disc
32	2	CMP15507	Meter Dial Spacer
33	1	CMP41418	Retractable Spring Plunger
34	1	CMP41477	Gate Handle
35	1	CMP41722	Metering Gate Shaft Assembly
36	1	CMP41723	Bronze Sprocket Assembly
37	1	CMP41724	Motor Sprocket Assembly
38	1	CMP41495	#40 Chain Belt Drive
39	1	CMP41417	#40 Chain Belt Idler Drive
40	1	CMP41471	#40 Chain Brush Drive
41	1	CMP41488	Left Side Panel Decal E-923
42	1	CMP41489	Right Side Panel Decal E-922
43	1	CMP41725	Brush Drive Chain Guard
44	1	CMP41726	Belt Drive Chain Guard

410SP DASHBOARD ASSEMBLY

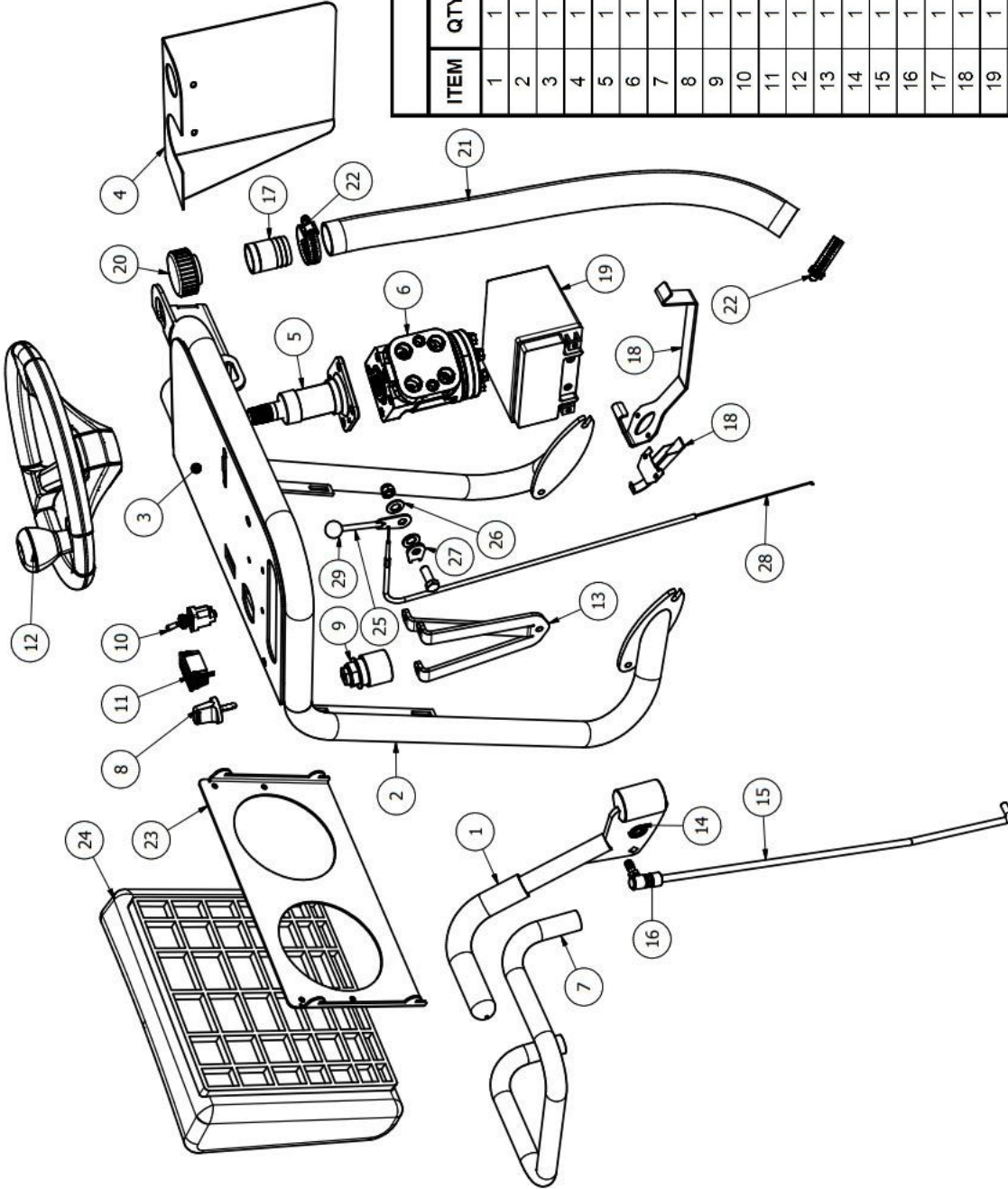

410SP DASHBOARD ASSEMBLY PARTS LIST			
ITEM	QTY	PART NUMBER	DESCRIPTION
1	1	CMP41708	Control Handle Assembly
2	1	CMP41709	Front Frame Assembly
3	1	CMP41487	Control Panel Decal E-924
4	1	CMP41075	Orbital Shield
5	1	CMP41408	Steering Column
6	1	CMP41402	Steering Orbital
7	1	CMP41606	Control Bar
8	1	CMP41474	Key
9	1	CMP41475	Key Switch and Nut
10	1	CMP41416	Toggle Switch
11	1	CMP41415	Hour Meter N310-0100-1018
12	1	CMP41407	Steering Wheel
13	1	CMP41054	Fwd/Rsv Mounting Assembly
14	1	CMP41419	R-Bearing 5/16 1603-2RS
15	1	CMP41220	Hydrostatic Rod
16	1	CMP41461	5/16 Ball Joint Linkage
17	1	CMP41232	Reservoir Fill Barb Fitting
18	1	CMP41090	Battery Strap
19	1	CMP41463	Battery Deka ETX 14L
20	1	CMP41493	Oil Cap
21	1	CMP41483	Clear Hose for Hydrostatic Fluid
22	2	CMP41482	2" Hose Clamp
23	1	CMP41055	Pad Mount
24	1	CMP41497	Hip Cushion Seat #2631633
25	1	CMP41727	Throttle Handle Assembly
26	2	CMP41432	Throttle Washer
27	1	CMP15100	Throttle Clip
28	1	CMP41457	Throttle Cable
29	1	CMP41431	Throttle Knob

410SP HYDROSTATIC FLUID RESERVOIR ASSEMBLY

410SP HYDROSTATIC FLUID RESERVOIR ASSEMBLY PARTS LIST			
ITEM	QTY	PART NUMBER	DESCRIPTION
1	1	CMP41704	Hydrostatic Fluid Reservoir
2	1	CMP41464	Hydrostatic Fluid Filter BT-8409
3	4	CMP41451	Fitting 6806-08-06
4	1	CMP41705	Reservoir Cleanout Assembly
5	1	CMP41078	Cleanout Cover
6	1	3/8-16 UNC - 1.5	Hex Cap Screw
7	1	CMP41433	Reservoir O Ring

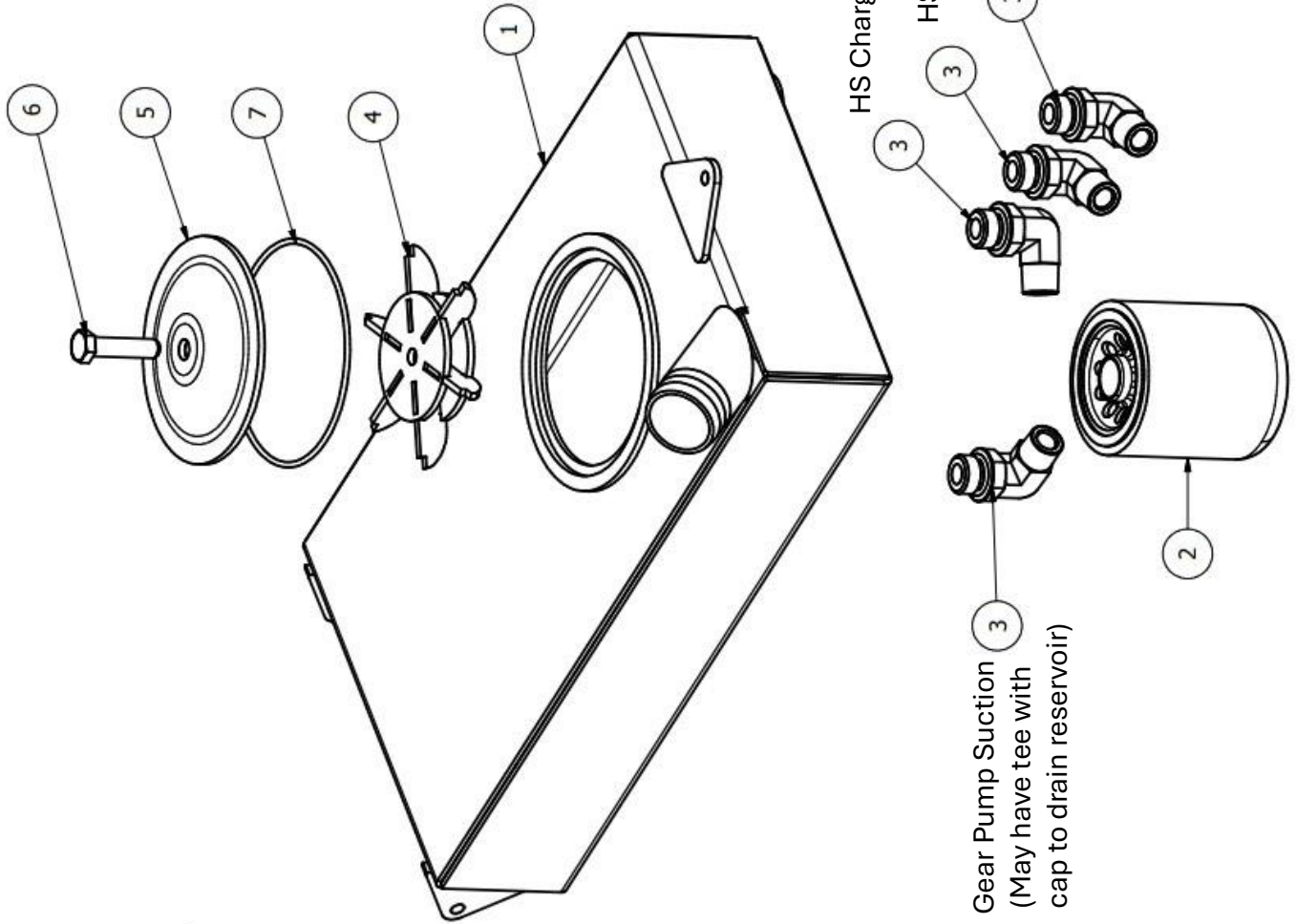

SCHEMATICS

ELECTRICAL SCHEMATIC

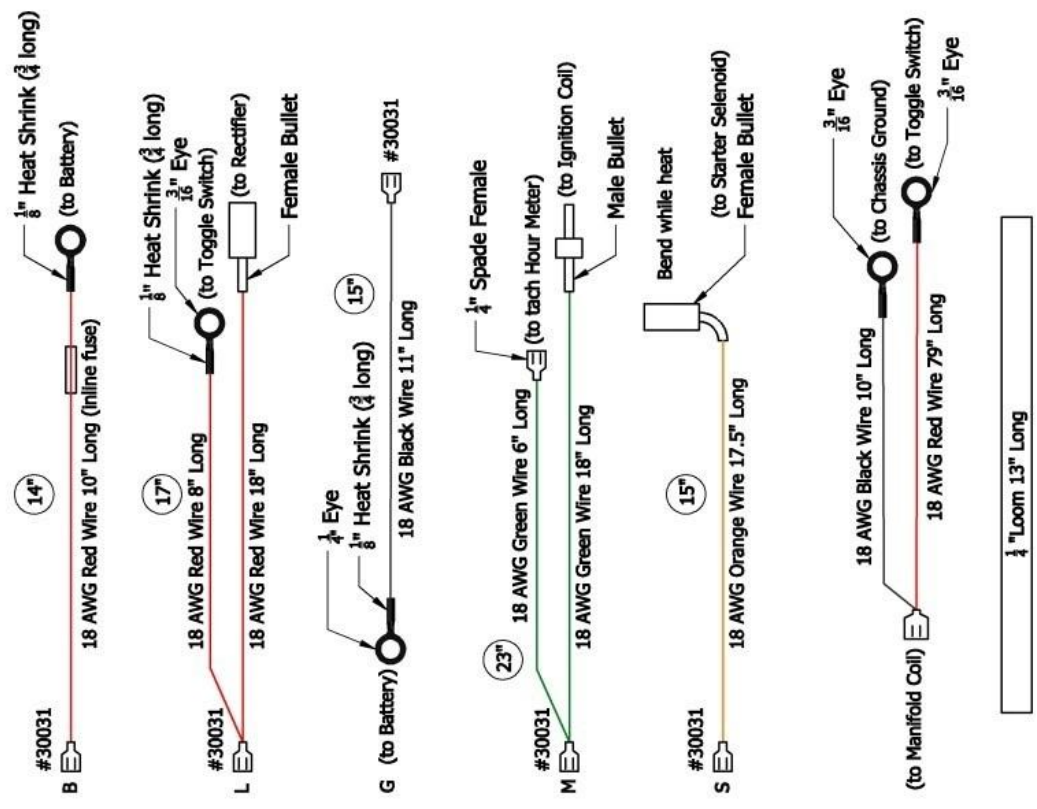
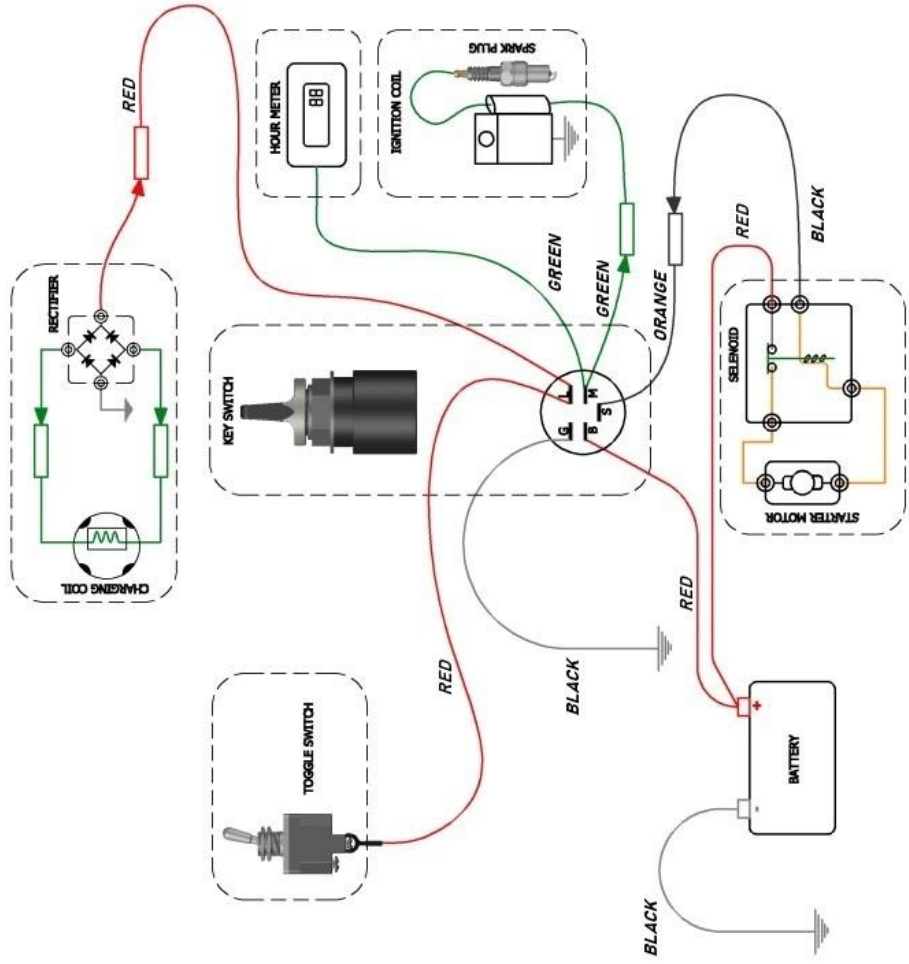

HYDROSTATIC FLUID SCHEMATIC

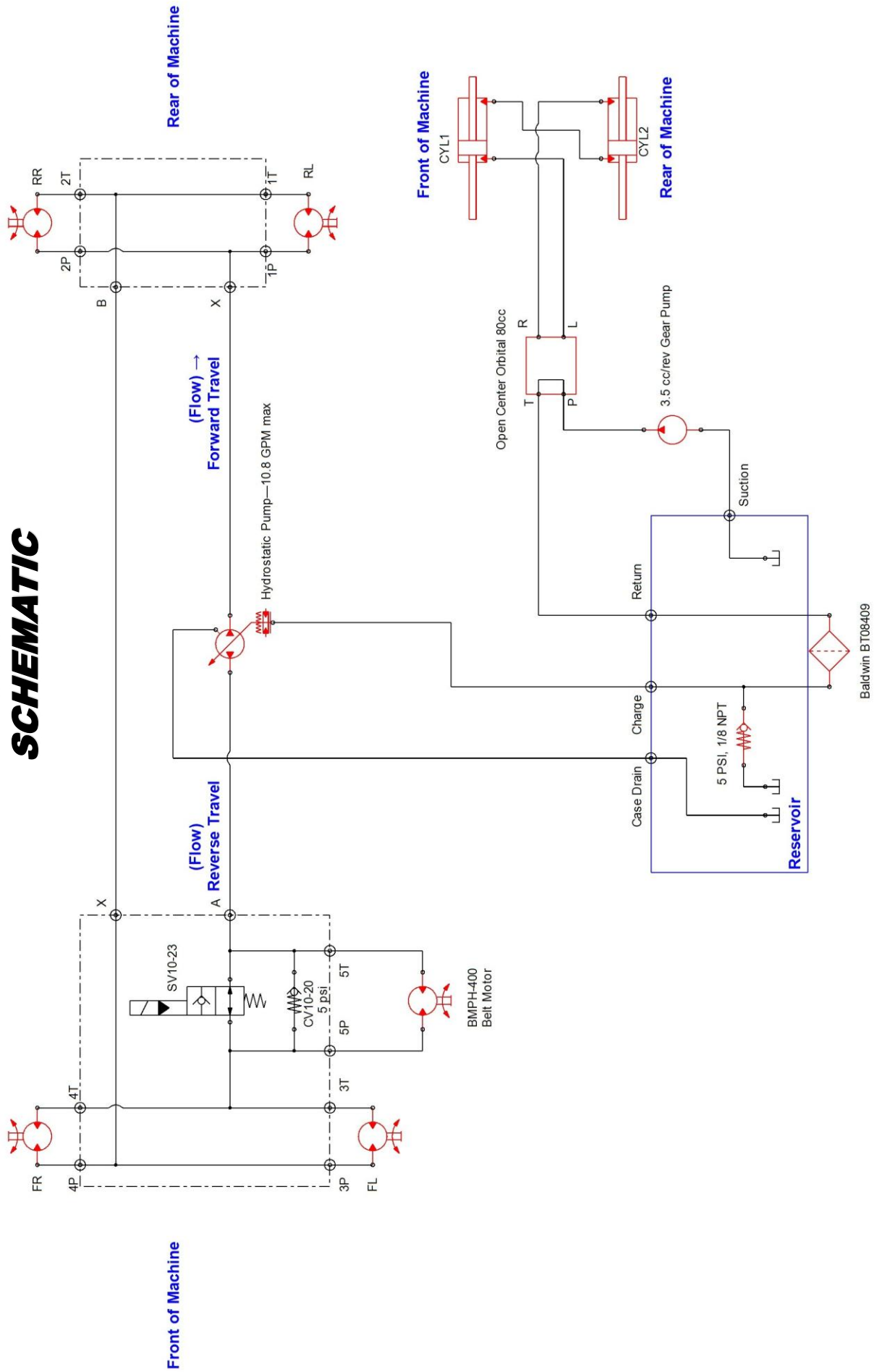

HYDROSTATIC HOSES

410SP 1/4" HYDROSTATIC HOSES			
ITEM	QTY	PART NUMBER	DESCRIPTION
1	1	CMP41814	Orbital L 1/4"x 53" Long
2	1	CMP41815	Orbital R 1/4"x 31" Long
3	1	CMP41816	Cylinder Link 1/4"x 30" Long

4G-4FJX

4G-6FJX 90M



①

4G-4FJX

6G-6FJX 90S



②

4G-4FJX

4G-4FJX



③

410SP 3/8" HYDROSTATIC HOSES			
ITEM	QTY	PART NUMBER	DESCRIPTION
1	4	CMP41802	Front Wheel Motor 3/8"x 15" Long
1	4	CMP41803	Rear Wheel Motor 3/8"x 11.5" Long
1	1	CMP41804	Case Drain 3/8"x 6" Long
2	1	CMP41805	Hydrostatic Charge 3/8"x 8.5" Long
3	1	CMP41806	Orbital T to Reservoir 3/8"x 30.5" Long
4	1	CMP41807	Gear Pump to Orbital P 3/8"x 17.5" Long

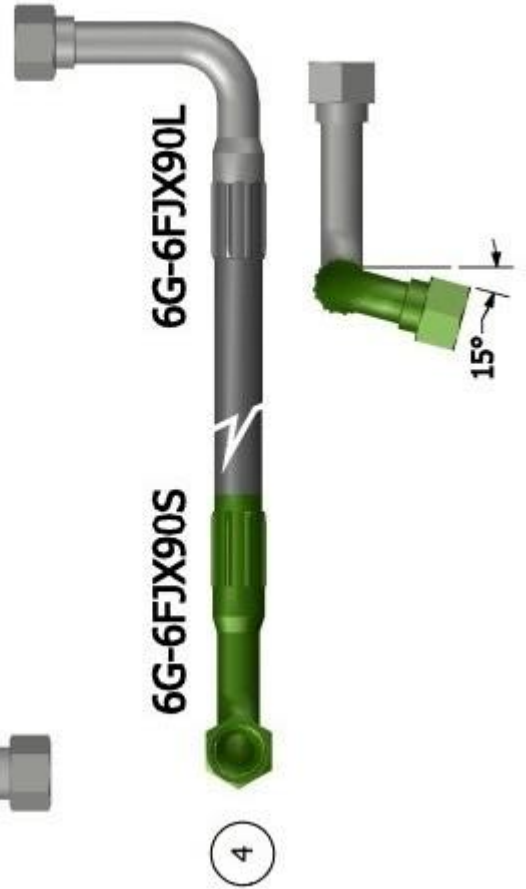
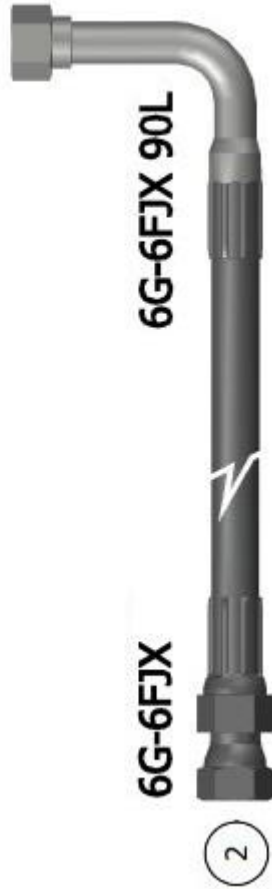



8G-8FJX 45

8G-8FJX

1

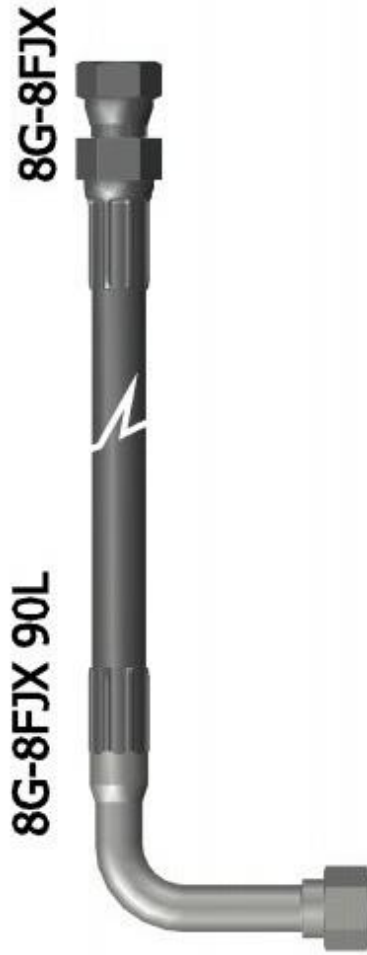

8G-8FJX 90L

8G-8FJX

2



8G-8FJX

8G-8FJX 90S

3



8G-6MP

8G-8FJX 90S

4

410SP 1/2" HYDROSTATIC HOSES				
ITEM	QTY	PART NUMBER	DESCRIPTION	
1	1	CMP41808	Hydrostat A to Manifold A 1/2"x 22.5" Long	
1	1	CMP41809	X Between Manifolds 1/2"x 31.5" Long	
2	1	CMP41810	Hydrostat B to Manifold B 1/2"x 5" Long	
3	1	CMP41811	Gear Pump Suction 1/2"x 7.5" Long	
4	1	CMP41812	Belt Motor 1/2"x 43" Long	
4	1	CMP41813	Belt Motor 1/2"x 44.5" Long	

Earth & Turf

America's Compact Topdresser Company

**1867 Kirkwood Pike
Kirkwood, Pennsylvania 17536
888-693-2638**

